

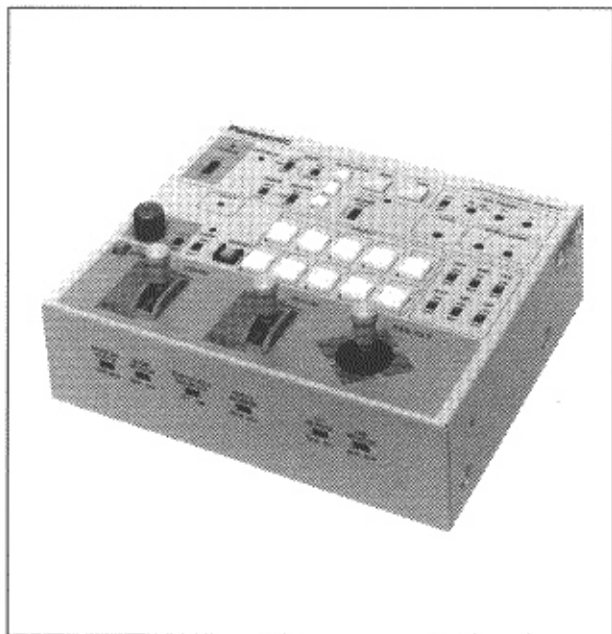

Hybrid Control Panel  
**AW-RP501**

# Operating Instructions



**Panasonic®**

Before attempting to connect or operate this product,  
please read these instructions completely.

	<b>CAUTION</b> RISK OF ELECTRIC SHOCK DO NOT OPEN	
<p><b>CAUTION:</b> TO REDUCE THE RISK OF ELECTRIC SHOCK, DO NOT REMOVE COVER (OR BACK). NO USER SERVICEABLE PARTS INSIDE. REFER SERVICING TO QUALIFIED SERVICE PERSONNEL.</p>		



SA 1965

The lightning flash with arrowhead symbol, within an equilateral triangle, is intended to alert the user to the presence of uninsulated "dangerous voltage" within the product's enclosure that may be of sufficient magnitude to constitute a risk of electric shock to persons.



SA 1966

The exclamation point within an equilateral triangle is intended to alert the user to the presence of important operating and maintenance (servicing) instructions in the literature accompanying the appliance.

For U.S.A.

**Warning:**

This equipment generates and uses radio frequency energy and if not installed and used properly, i.e., in strict accordance with the instruction manual, may cause harmful interference to radio communications. It has been tested and found to comply with the limits for a Class A computing device pursuant to Subpart J of Part 15 of FCC Rules, which are designed to provide reasonable protection against such interference when operated in a commercial environment.

For CANADA

This digital apparatus does not exceed the Class A limits for radio noise emissions from digital apparatus set out in the Radio Interference Regulations of the Canadian Department of Communications.

The serial number of this product may be found on the bottom of the unit.

You should note the serial number of this unit in the space provided and retain this book as a permanent record of your purchase to aid identification in the event of theft.

Model No. \_\_\_\_\_

Serial No. \_\_\_\_\_

**WARNING:**

TO PREVENT FIRE OR ELECTRIC SHOCK HAZARD, DO NOT EXPOSE THIS APPLIANCE TO RAIN OR MOISTURE.

## CONTENTS

FEATURES .....	2
PRECAUTIONS .....	3
MAJOR OPERATING CONTROLS AND THEIR FUNCTIONS .....	4
INSTALLATION OF PAN/TILT HEAD .....	18
CONNECTIONS .....	21
OPERATING PROCEDURES .....	25
RACK MOUNTING .....	33
SPECIFICATIONS .....	35
ACCESSORIES .....	36

# FEATURES

- The Hybrid Control Panel AW-RP501 controls the Pan/tilt Head (AW-PH300) and Color Video Camera (WV-E550 or AW-E560). With three coaxial cables (5C-2V) and a single 10BASE-T straight cable (UTP category 5), this panel performs various kinds of control on the camera and pan/tilt head, and sends and receives camera video signals and genlock signals.
- The maximum distance from this control panel to the camera and pan/tilt head is 500 meters.
- Head pan/tilt and lens zoom/focus can be controlled at varying speeds with the servo control, and can be pre-set at up to 10 points.
- With the auxiliary control input connector (AUX CONTROL IN), pan/tilt, zoom, focus, and iris operations can be externally controlled.

# PRECAUTIONS

- **Use only with AC Adaptor, Model AW-PS301.**
- **Handle the control panel with care.**  
Dropping the control panel or subjecting it to a strong shock can cause a failure or an accident.
- **Operating temperature range  $-10^{\circ}\text{C}$  to  $+45^{\circ}\text{C}$**   
Avoid using it in a cold place below  $-10^{\circ}\text{C}$  or a hot place above  $+45^{\circ}\text{C}$  because low or high temperature will adversely affect the parts inside.
- **Switch power off before power cable connection or disconnection.**  
Be sure to switch power off before connecting or disconnecting the power cable.
- **Avoid outdoor use.**
- **Install the control panel more than 1 meter away from the monitors.**

- **Care**

Pull out the power cable plug, and wipe the control panel clean with a dry cloth. If it is extremely dirty, dip a cloth into a diluted solution of kitchen detergent, squeeze it hard, and wipe the product surfaces carefully.

#### Note

- Do not use benzine, paint thinner, or other volatile liquids.
- When using a chemical duster, carefully read the caution notes on its use.

#### Precautions in Using Halogen Lamp

Set the power control switch to the OFF position after setting the lamp switch to the OFF position. Halogen lamp power will not be switched off if the AC adaptor for the AW-RP501 is disconnected or if the main circuit breaker is opened while the halogen lamp is in use.

# MAJOR OPERATING CONTROLS AND THEIR FUNCTIONS

## ■ Control Panel

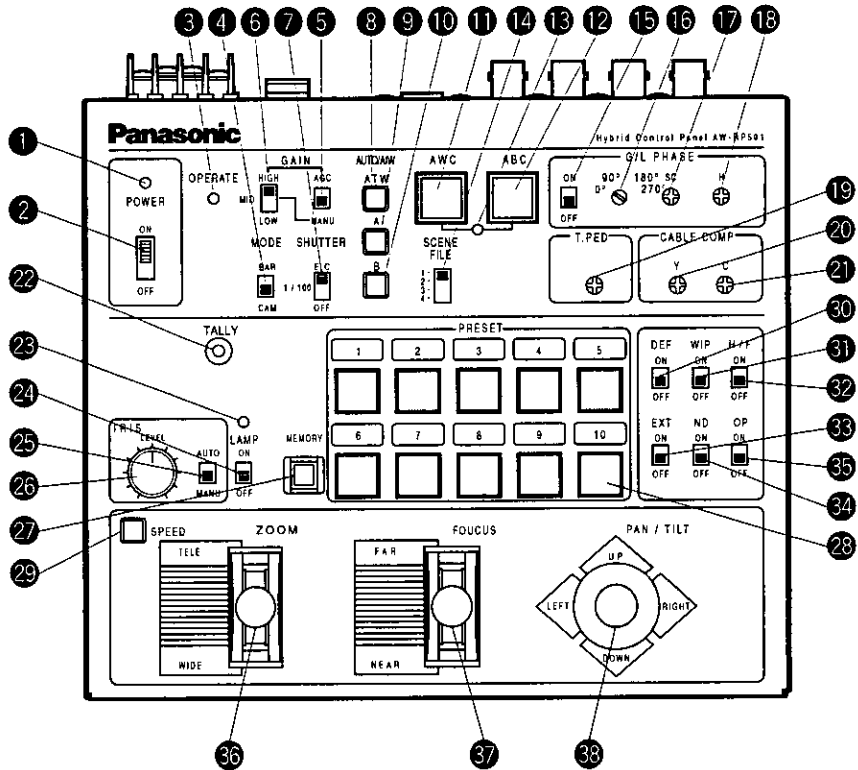

**❶ Power Indicator [POWER]**

Lights red when POWER ON/OFF Switch ❷ is in the ON position, and goes out when the same switch is set to the OFF position.

**❷ Power Control Switch [POWER, ON/OFF]**

The camera and pan/tilt head are switched on when this switch is set to the ON position. (The power indicator lights.) The camera and pan/tilt head are partially switched off when this switch is set to the OFF position.

**Note:** When the switch is set to the OFF position, the camera is totally switched off but the communication line between the pan/tilt head and this control panel remains live. To disconnect all power supply, pull out the power plug from the electrical outlet.

**❸ Operating Indicator [OPERATE]**

Lights green when communication begins normally between the camera and the control panel, and goes out if a communication error occurs.

**❹ Mode Selection Switch [MODE, BAR/CAM]**

Used to select camera color bar signals or camera video signals. With the switch set to BAR, the control panel outputs color bar signals from the video output terminal. When the switch is set to CAM, it outputs camera video signals.

**❺ AGC Selection Switch [GAIN, AGC/MANU]**

Keep this switch in the AGC position if you want to keep automatic gain control. When this switch is at AGC, GAIN H/M/L Switch ❻ is invalid.

**❻ High Gain Selection Switch [GAIN, HIGH/MID/LOW]**

This switch is valid only when GAIN AGC/MANU Switch ❺ is in the MANU position. Normally, keep it in the LOW position. When the camera is used in a dark place or when video output level is not high enough even if the iris is wide open, set the switch to the MID or HIGH position.

**❼ Electronic Shutter Speed Selection Switch [SHUTTER, ELC/ 1/100 /OFF]**

Used to select a mode of camera electronic shutter control. With the switch in the ELC position, the electronic shutter is controlled and the camera sensitivity is automatically adjusted when using the camera in a bright place. The shutter speed is 1/100 second when the switch is in the 1/100 position. The electronic shutter is off when the switch is in the OFF position.

**❽ White Balance ATW Selection Switch [AUTO/ATW, ATW]**

When the switch is depressed, the camera keeps automatically adjusting white balance. The switch lights when it is selected.

**9 White Balance Ach Selection Switch  
[AUTO/ATW, A]**

When this switch is depressed, white balance will be as stored in Channel A of the camera. The switch lights when it is selected. When AWC Switch 11 is pressed after selecting AUTO/ATW, A, white balance is automatically adjusted and stored in Channel A.

**10 White Balance Bch Selection Switch  
[AUTO/ATW, B]**

When this switch is depressed, white balance will be as stored in Channel B of the camera. The switch lights when it is selected. When AWC Switch 11 is pressed after selecting AUTO/ATW, B, white balance is automatically adjusted and stored in Channel B.

**11 Auto White Start Switch [AWC]**

If this switch is pressed when AUTO/ATW A Switch 9 or AUTO/ATW B Switch 10 is selected, white balance is automatically adjusted. The adjustment results are stored in Channel A or B. This switch is invalid if the MODE BAR/CAM Switch 4 is in the BAR position. Auto Set Indicator 13 flashes while AWC is in operation, and goes out when white balance has been properly adjusted. Auto Set Indicator 13 remains lit if white balance adjustment fails.

**Note:** White balance may not be adjustable if there is no white in the image being taken by the camera. For details, refer to the Operating Instructions for the Camera.

**12 Auto Black Start Switch [ABC]**

When this switch is depressed, the lens iris is automatically closed to set black balance. Be sure to keep the IRIS AUTO/MANU Switch 25 in the AUTO position in setting black balance. Auto Set Indicator 13 flashes while ABC is in operation, and goes out when black balance has been properly adjusted. Auto Set Indicator 13 remains lit if black balance adjustment fails. Black balance adjustment may fail if the total pedestal is too low. In such a case, adjust the total pedestal with T.PED Control 19 (referring to the OPERATING PROCEDURES at page 25) and try to adjust black balance again.

**13 Auto Set Indicator**

This LED flashes during white balance or black balance adjustment with AWC Switch 11 or ABC Switch 12 depressed, and goes out when the adjustment has ended normally. The LED remains lit if balance adjustment fails.

**14 Scene File Selection Switch [SCENE FILE, 1/2/3/4]**

Select a scene file preset on the camera side. Remember, however, that [4] is camera scene file USER A or USER B (provided that WV-E550 or AW-E560 is connected).



**15 Genlock Phase Control Switch**  
**[G/L PHASE, ON/OFF]**

Used to adjust the genlock phase in operating the camera in external sync mode. Set the switch to the ON position only when adjusting the genlock subcarrier phase or genlock horizontal phase. Otherwise, keep the switch in the OFF position.

**16 Genlock Subcarrier Phase Coarse Switch**  
**[G/L PHASE, 0°/90°/180°/270°]**

Used for coarse adjustment of the color phases of genlock input and video output signals in operating the camera in external sync mode. Used in combination with G/L PHASE SC Control 17, the switch has an adjustment range of over 360°. Set G/L PHASE ON/OFF Switch 15 to the ON position before adjusting the color phases with this switch.

**17 Genlock Subcarrier Phase Fine Control**  
**[G/L PHASE, SC]**

Used for fine adjustment of the color phases of genlock input and video output signals in operating the camera in external sync mode. Use this switch in combination with G/L PHASE Coarse Switch 16. Set G/L PHASE ON/OFF Switch 15 to the ON position before adjusting the color phases with this switch.

**18 G/L Horizontal Phase Adjustment Control**  
**[G/L PHASE, H]**

Used to adjust the horizontal phases of genlock input and video output signals in operating the camera in

external sync mode. Set G/L PHASE ON/OFF Switch 15 to the ON position before adjusting the horizontal phases with this switch.

**19 Total Pedestal Level Control [T. PED]**

The set pedestal level of the camera's Y (luminance) signal can be adjusted. This control is used in a system of two or more cameras to adjust the pedestal levels of these cameras. The control may operate not continuous sometimes due to digital signal processing.

**20 Cable Compensation Luminance Control**  
**[CABLE COMP, Y]**

Used to adjust the Y (luminance) signal level of video output signals as appropriate to the cable length between the pan/tilt head and this control panel. To adjust it, first set MODE BAR/CAM Switch 4 to the BAR position, then connect a waveform monitor, vectorscope, or other measuring instrument to the video signal output. If the cable between the pan/tilt head and this control panel is longer than 300 meters, set the cable compensation switch on the pan/tilt head to the ON position in advance. (For details, refer to the OPERATING PROCEDURES at page 25 or to the Operating Instructions for the Pan/tilt Head.) First, adjust the Y (luminance) signal level with this control, then adjust the C (chrominance) signal level with CABLE COMP C Control 21. Repeat this until the video output level of this control panel matches the camera output level.

Turning this control changes not only the Y (luminance) signal level but also the whole video signal level.

### 21 **Cable Compensation Chrominance Control [CABLE COMP, C]**

Used to adjust the C (chrominance) signal level of video output signals as appropriate to the cable length between the pan/tilt head and this control panel. To adjust it, first set MODE BAR/CAM Switch 4 to the BAR position, then connect a waveform monitor, vectoroscope, or other measuring instrument to the video signal output. If the cable between the pan/tilt head and this control panel is longer than 300 meters, set the cable compensation switch on the rotary head to the ON position in advance. (For details, refer to the OPERATING PROCEDURES at page 25 or to the Operating Instructions for the Pan/ Tilt Head.) First, adjust the Y (luminance) signal level with CABLE COMP Y Control 20, then adjust the C (chrominance) signal level with this control. Repeat this until the video output level of this control panel matches the camera output level.

### 22 **Tally Indicator [TALLY]**

Lights red when a tally signal is input to TALLY Terminal 39 from a Special Effect Generator (SEG) or video switcher.

### 23 **Lamp Indicator [LAMP]**

Lights red when LAMP ON/OFF Switch 24 is in the ON position. Flashes if the lamp connected to the AC Adapter (AW-PS300) for pan/tilt head is broken. Goes out when LAMP ON/OFF Switch 24 is set to the OFF position.

**Note:** Use a halogen lamp of 250 W to 500 W to connect to the Pan/tilt Head AC Adapter (AW-PS300). If a lamp of lower than 250 W is connected to it, the LED may flash when LAMP ON/OFF Switch 24 is in the ON position even though the lamp is not broken.

### 24 **Lamp Switch [LAMP, ON/OFF]**

Switches on and off the halogen lamp connected to the lamp AC receptacle of the Pan/tilt Head AC Adapter (AW-PS300). Set it to the ON position to switch the halogen lamp on (in which case, the lamp LED flashes). Set it to the OFF position to switch the halogen lamp off.

### 25 **Lens Iris Selection Switch [IRIS, AUTO/MANU]**

When this switch is in the AUTO position, the lens iris is automatically controlled according to the quantity of light entering the lens. When the switch is in the MANU position, the iris can be manually controlled over the range from the closed position to the fully open position using IRIS LEVEL Control 26.

Set the switch to the MANU position in storing iris data in PRESET Switches 28 with MEMORY Switch 27. If the switch is in the AUTO position, iris data will not be stored in the memory.

### **26 Lens Iris Control [IRIS, LEVEL]**

When IRIS AUTO/MANU Switch 25 is in the MANU position, the iris can be controlled over the range from the closed position to the fully open position using this control. Turning it clockwise opens the iris and turning it counterclockwise closes the iris.

If the camera is preset to AUTO IRIS ADJ ON when IRIS AUTO/MANU Switch 25 is in the AUTO position, this control may be used for fine adjustment of ALC focus level. For details, refer to the Operating Instructions for the Camera.

If the preset memory is called by pressing PRESET Switches 28 when IRIS AUTO/MANU Switch 25 is in the MANU position, the iris is adjusted to the preset value stored in the memory regardless of the position of this control. If the control is turned after that, the iris is adjusted corresponding to the position of the control.

### **27 Preset Memory Switch [MEMORY]**

Head pan/tilt positions, lens zoom/focus/iris (provided that IRIS AUTO/MANU Switch 25 is in the MANU position), and camera white balance (ATW Channel A or B) can be preset in up to 10 memory buttons.

To preset them in these buttons, first select a head pan/tilt position, lens zoom/focus/iris, or camera white balance (ATW or Channel A or B); press MEMORY Switch 27 (so it lights yellow green and all the 10 buttons of PRESET Switches 28 flash); while keeping the MEMORY Switch 27 depressed, press one of the 10 buttons of PRESET Switch 28 as desired. The pressed button in which the selected item is stored lights.

### **28 Preset Position Selection Switches [PRESET]**

The head pan/tilt positions, lens zoom/focus/iris, and camera white balance that are stored in the buttons of PRESET Switch 28 can be recalled to operate the pan/tilt head, the lens, and the camera according to the preset data.

To preset them in the PRESET switches, first select a head pan/tilt position, lens zoom/focus/iris, or camera white balance (ATW or Channel A or B); press the MEMORY Switch 27 (so it lights yellow green and all the 10 buttons of PRESET Switches 28 flash); at the same time press one of the 10 buttons of PRESET Switches 28 as desired. The pressed button in which the selected item is stored lights.

### **29 Speed Selection Switch [SPEED]**

If ZOOM lever 36, FOCUS Lever 37, or PAN/TILT Lever 38 is moved while keeping SPEED Switch 29 depressed, the corresponding operation takes place at low speed, provided that SPEED SW CHANGE Switch 50 is in the LOW position. If one of these levers is moved with SPEED Switch 29 depressed when SPEED SW CHANGE Switch 50 is in the HIGH position, the corresponding operation takes place at high speed. SPEED Switch 29 remains lit while it is kept depressed.

**30 Defroster Switch [DEF, ON/OFF]**

If this switch is connected to a pan/tilt head with a built-in defroster function, it switches on and off the defroster.

**31 Wiper Switch [WIP, ON/OFF]**

If this switch is connected to a pan/tilt head with a built-in wiper function, it switches on and off the wiper.

**32 Heater/Fan Switch [H/F, ON/OFF]**

If this switch is connected to a pan/tilt head with a built-in heater or fan function, it switches on and off the heater or fan.

**33 Lens Extender Switch [EXT, ON/OFF]**

If this switch is connected to a lens with a built-in extender function, it switches on and off the lens extender. For details, refer to the Operating Instructions for the Lenses and Pan/tilt Head.

**34 ND Filter Switch [ND, ON/OFF]**

If this switch is connected to a lens with a built-in ND filter function, it switches on and off the ND filter. For details, refer to the Operating Instructions for the Lenses and Pan/tilt Head.

**35 Option Switch [OP, ON/OFF]**

Controls the option switch terminal on the Pan/tilt Head AC Adapter (AW-PS300) to short circuit or open it. That is, the option switch terminal is shorted when OP

ON/OFF Switch **35** is in the ON position, or is opened when it is in the OFF position. For details, refer to the Operating Instructions for the Pan/tilt Head AC Adapter.

**36 Zoom Lever [ZOOM, TELE/WIDE]**

Controls the lens zoom. Zoom speed varies according to the angle of the lever. The lens moves toward TELE when the lever is moved toward TELE, or toward WIDE when the lever is moved toward WIDE, provided that ZOOM REVERSE Switch **51** is in the NOR position. When ZOOM REVERSE Switch **51** is set to the REV position, the lens moves in the opposite direction. ZOOM/FOCUS EXCHANGE Switch **52** may be used to exchange its function with FOCUS Lever **37**.

**37 Focus Lever [FOCUS FAR/NEAR]**

Used to adjust the lens focus at varying speed depending on the angle of the lever. The lens is focused far when the lever is moved toward FAR, or near when the lever is moved toward NEAR, provided that FOCUS REVERSE Switch **53** is in the NOR position. When FOCUS REVERSE Switch **53** is set to the REV position, the lens focus operates in the opposite direction. ZOOM/FOCUS EXCHANGE Switch **52** may be used to exchange its function with ZOOM Lever **36**.

**38 Pan/tilt Lever [PAN/TILT, UP/DOWN/LEFT/RIGHT]**

Controls the head's pan/tilt operation at varying speed depending on the angle of the lever. The pan/tilt head turns up when the lever is moved toward UP, or down when it is moved toward DOWN, provided that TILT REVERSE Switch 54 is in the NOR position. The pan/tilt head moves in the opposite direction if the TILT REVERSE Switch 54 is in the REV position. The pan/tilt head turns leftward when the lever is moved toward LEFT, or rightward when it is moved toward RIGHT, provided that PAN REVERSE Switch 55 is in the NOR position. The pan/tilt head moves in the opposite direction if the PAN REVERSE Switch 55 is in the REV position.

**Note:** TILT REVERSE Switch 54 and PAN REVERSE Switch 55 may be used to reverse the operating direction of the pan/tilt head, but be sure to set the operating direction of the pan/tilt head with its mounting direction selection switch during its installation depending on whether the pan/tilt head is mounted on the floor or is suspended. Unless the mounting direction selection switch on the pan/tilt head is properly set, the pan/tilt head will pan or tilt in the opposite direction and the pan/tilt head operation limiters will not be properly stored in the memory. For details on the setting of this switch, refer to INSTALLATION OF PAN/TILT HEAD at page 18 or the Operating Instructions for the Pan/tilt Head.

## ■ REAR PANEL

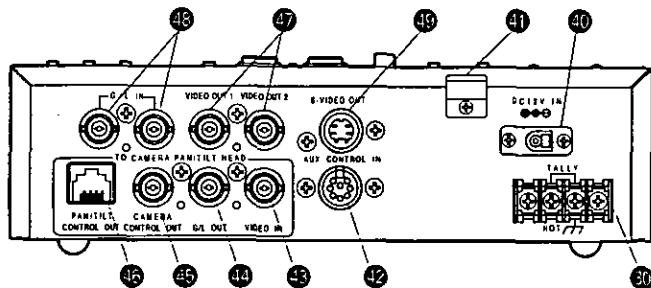

### 39 TALLY Input Terminal [TALLY] (2-pin Terminal Board)

Connect it to the tally connector on a special effect generator (SEG) or a video switcher, for example. When [HOT] terminal falls to ground level, TALLY Indicator 22 and the tally indicator on the Pan/tilt Head (AW-PH300) light red.

### 40 12V DC Input Connector [DC 12V IN] (DC Jack)

Connect the AC Adaptor AW-PS301 (optional).

### 41 Cord Clamp (Clamper)

Clamps the DC cord of the AC Adapter AW-PS301 (optional) connected to DC 12V IN Connector 40 to prevent its disconnection.

### 42 Auxiliary Control Input Connector [AUX CONTROL IN] (8-pin DIN Connector)

External control signals are input to this connector in controlling the head's pan/tilt, lens zoom, focus and iris operations.

**Note:** In externally controlling the pan/tilt head and lens through this connector, set IRIS LEVEL Control 26 on this control panel to the center point (straight up), and do not simultaneously operate SPEED Switch 29, ZOOM Lever 36, FOCUS Lever 37, and PAN/TILT Lever 38. Operation errors may occur if external controls are simultaneously used.

8-pin DIN connector  
pin assignment  
(as viewed from the  
rear of the control panel)

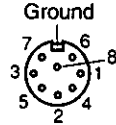

Example of auxillary  
control circuit

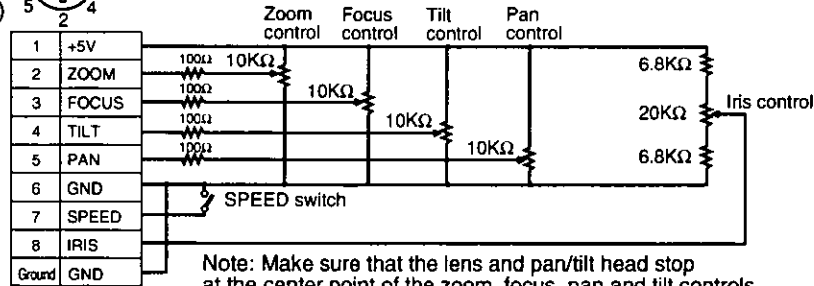

Note: Make sure that the lens and pan/tilt head stop  
at the center point of the zoom, focus, pan and tilt controls  
(or at the lever reset position if the controls have a lever reset function).

#### 43 VIDEO Input Connector

[TO CAMERA PAN/TILT HEAD, VIDEO IN]  
(BNC Connector)

Connect it to the video output connector [VIDEO OUT] on the pan/tilt head with a coaxial cable (5C-2V or equivalent), which may be extended up to 500 meters.

#### 44 Genlock Output Connector

[TO CAMERA PAN/TILT HEAD, G/L OUT]  
(BNC Connector)

Connect it to the G/L input connector [G/L IN] on the pan/tilt head with a coaxial cable (5C-2V or equivalent) in operating the camera in external sync mode. The cable can be extended up to 500 meters.

#### 45 Camera Control Output Connector

[TO CAMERA, PAN/TILT HEAD CAMERA CONTROL  
OUT] (BNC Connector)

Connect it to camera control input connector [CAMERA CONTROL IN] on the pan/tilt head with a coaxial cable (5C-2V or equivalent), which may be extended up to 500 meters.

#### 46 Pan/tilt Control Output Connector

[TO CAMERA PAN/TILT HEAD, PAN/TILT CONTROL  
OUT] (RJ-45 8-pin Modular Jack)

Connect it to pan/tilt control output connector [P/T CONTROL IN] on the pan/tilt head with a 10BASE-T straight cable (UTP category 5 or equivalent), which may be extended up to 500 meters.

**47 Video Output Connectors**

**[VIDEO OUT 1, VIDEO OUT 2] (BNC Connector)**

Video signals adjusted by the cable compensation circuit according to the cable length from the rotary head to the control panel are output. There are two output connectors to be connected to a monitor, special effect generator (SEG), VCR, or other video input devices with coaxial cables.

**48 Genlock Input Connectors**

**[G/L IN] (BNC Connector)**

Black burst signals are input to one of the two connectors in operating the camera in external sync mode. The two connectors are automatically terminated, so input the above signals to one of them and use the other as a loop-through output.

**49 S-Video Output Connector**

**[S-VIDEO OUT] (4-pin S-Connector)**

Y (luminance) and C (chrominance) signals are output. Connect it to the S-video input on a monitor or S-VHS VCR, for example.



## ■ Front Panel

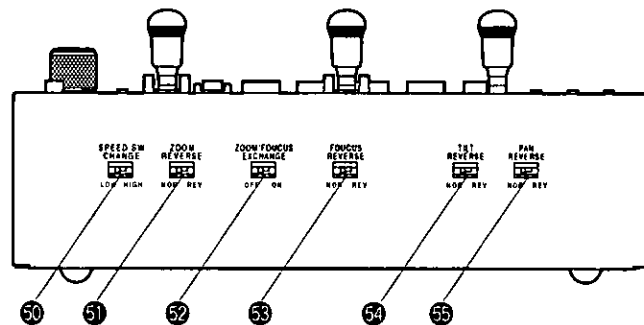

### 50 Speed Switch Changing Switch [SPEED SW CHANGE, LOW/HIGH]

Changes the polarity of SPEED Switch 29. If ZOOM lever 36, FOCUS Lever 37, or PAN/TILT Lever 38 is moved while keeping SPEED Switch 29 depressed, the corresponding operation takes place at low speed, provided that SPEED SW CHANGE Switch 50 is in the LOW position. If one of these levers is moved with SPEED Switch 29 depressed when SPEED SW CHANGE Switch 50 is in the HIGH position, the corresponding operation takes place at high speed.

The speed polarity can also be changed by pressing SPEED Switch 29 while keeping MEMORY Switch 27 depressed. When this step is taken again, the original speed polarity is restored. Take this step if it is difficult to shift SPEED SW CHANGE Switch 50 because this control panel is mounted on a console or the like.

### 51 Zoom Reverse Switch [ZOOM REVERSE, NORM/REV]

Changes the operating direction of ZOOM Lever 36. The lens zoom moves toward TELE when ZOOM Lever 36 is moved toward WIDE, or toward WIDE when it is moved toward TELE, provided that ZOOM REVERSE Switch 51 is in the NOR position. When ZOOM REVERSE Switch 51 is set to the REV position, lens zoom operation takes place in the opposite direction. With ZOOM REVERSE Switch 51 in the REV position, the operating directions shown on the panel are reversed. In this case, paste the supplied seal on the panel.

### **52 Zoom/Focus Exchange Switch**

#### **[ZOOM/FOCUS EXCHANGE, ON/OFF]**

ZOOM Lever 36 and FOCUS Lever 37 exchange their function between them when this switch is set to the ON position. Unless this exchange is needed, keep the switch in the OFF position.

With ZOOM/FOCUS EXCHANGE Switch 52 in the ON position, the operations shown on the panel do not agree with the indications on the panel. In this case, paste the supplied seal on the panel.

### **53 Focus Reverse Switch**

#### **[FOCUS REVERSE, NOR/REV]**

Changes the operating direction of FOCUS Lever 37. The lens is focused far when FOCUS Lever 37 is moved toward FAR, or near when the lever is moved toward NEAR, provided that FOCUS REVERSE Switch 53 is in the NOR position. When FOCUS REVERSE Switch 53 is set to the REV position, the lens focus operates in the opposite direction.

With FOCUS REVERSE Switch 53 in the REV position, the operating directions shown on the panel are opposite to the indications on the panel. In this case, paste the supplied seal on the panel.

### **54 Tilt Reverse Switch [TILT REVERSE, NOR/REV]**

Changes the tilt direction controlled by PAN/TILT Lever 38. The pan/tilt head turns up when PAN/TILT Lever 38 is moved toward UP, or down when it is moved toward DOWN, provided that TILT REVERSE Switch 54 is in

the NOR position. The pan/tilt head moves in the opposite direction if the TILT REVERSE Switch 54 is in the REV position.

With TILT REVERSE Switch 54 in the REV position, the operating directions shown on the panel are opposite to the indications on the panel. In this case, paste the supplied seal on the panel.

### **55 Pan Reverse Switch [PAN REVERSE, NOR/REV]**

Changes the pan direction controlled by PAN/TILT Lever 38. The pan/tilt head turns leftward when PAN/TILT Lever 38 is moved toward LEFT, or rightward if it moved toward RIGHT. The rotary head turns in the opposite direction if the PAN REVERSE Switch 55 is in the REV position, provided that PAN REVERSE Switch 55 is in the NOR position. When PAN REVERSE Switch 55 is set to the REV position, the pan/tilt head turns in the opposite directions.

With PAN REVERSE Switch 55 in the REV position, the operating directions shown on the panel are opposite to the indications on the panel. In this case, paste the supplied seal on the panel.

**Note:** TILT REVERSE Switch 54 and PAN REVERSE Switch 55 may be used to reverse the operating direction of the pan/tilt head, but be sure to set the operating direction of the pan/tilt head with its mounting direction selection switch during its installation depending on whether the pan/tilt head is mounted on the floor or is suspended. Unless the mounting direction selection switch on the

pan/tilt head is properly set, the pan/tilt head will pan or tilt in the opposite direction and the pan/tilt head operation limiters will not be properly stored in the memory. For details on the setting of this switch, refer to INSTALLATION OF PAN/TILT HEAD at page 18 or the Operating Instructions for the Pan/tilt Head.

# INSTALLATION OF PAN/TILT HEAD

- Install the pan/tilt head after carefully reading the Operating Instructions for Pan/tilt Head.
- Have four hex bolts (M6 x 4) ready for mounting the pan/tilt head. Select bolts of a length appropriate to the material and structure of the mounting base and the overall weight applied to it. Fasten the bolts securely with plain washers, spring washers, and hex nuts. If the bolts are not securely tightened, the pan/tilt head might fall to cause injuries or accidents. In case of suspending the pan/tilt head, locally purchase a wire rod strong enough to hold the pan/tilt head, camera, and lenses, pass it through the wire hole opened in a firm board, such as of the ceiling, for example, and fasten it securely.
- The switches on the pan/tilt head have been preset before shipment from the factory on the assumption that the pan/tilt head would be suspended from the ceiling. If the pan/tilt head is mounted on a board, for example, be sure to shift the mounting direction switches on the pan/tilt head. Unless this is done, pan/tilt directions will be reversed and pan/head operation limiter data cannot be properly stored in the memory. For details on shifting these switches, refer to the Operating Instructions for Pan/tilt Head.

Have a strong enough wire rod head and fasten it securely to a firm board, such as of the ceiling.

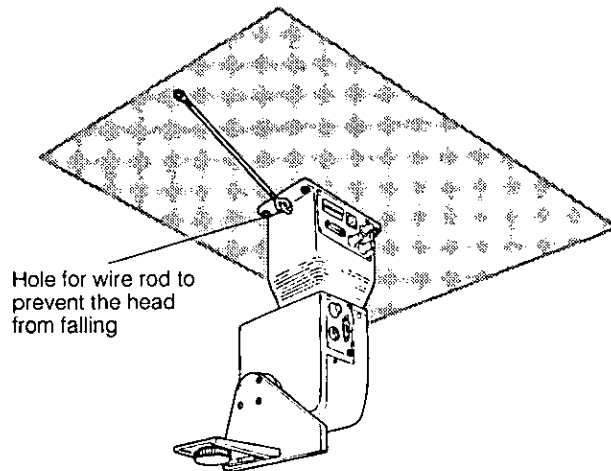

- **Changing Switch Settings on Pan/tilt Head**

- ① Remove the cover from the pan/tilt head.
  - \* Be careful of the Tally Indicator wire.

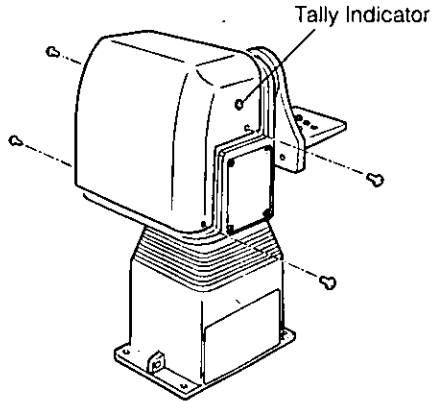

- ③ Place the cover back on the pan/tilt head.
  - \* Be sure not to trap the wires.

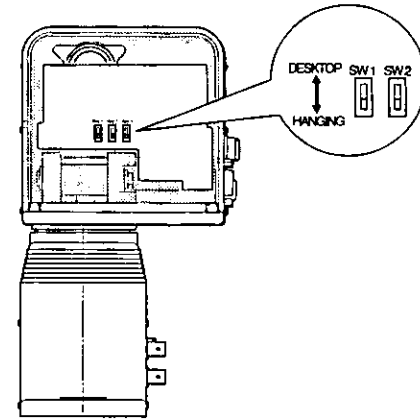

- ② Shift the mounting direction switches (SW1, SW2) on the pan/tilt head depending on whether the head is suspended from the ceiling or mounted on the floor. They are originally set for suspended installation.
  - \* Do not shift SW3, which is originally set to OFF. If SW3 is shifted from the original position, no operations can be controlled from the control panel.

- If the pan/tilt head is connected to the control panel with a cable longer than 300 meters, set the cable compensation switch on the pan/tilt head to the ON position in advance. If the distance between the pan/tilt head and the control panel is shorter than 300 meters, keep the switch in the original position (OFF). For details on shifting the switch, refer to the figure below or the Operating Instructions for Pan/tilt Head.

- **Shifting Cable Compensation Switch on Pan/tilt Head**

If the distance from the control panel to the pan/tilt head is longer than 300 meters, set the cable compensation switch to the ON position by observing the following procedure.

- ① Remove the controller connection panel from the pan/tilt head.
  - \* Be careful of the wires.
- ② Shift the cable compensation switch on the inner side of the controller connection panel of the pan/tilt head to the ON position.
- ③ Place the controller connection panel back on the pan/tilt head.

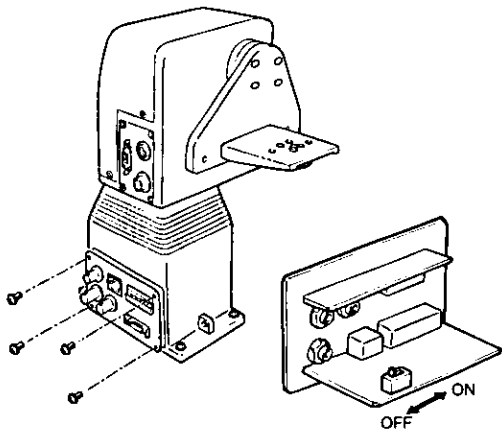

- **Lens Mounting**

- Turn the lens lock ring knob fully counterclockwise.
- If the lens mount has a cap, remove the cap.
- With the lens positioning pin up, mount the lens.
- Turn the lens lock ring knob clockwise till the lens is securely fastened.

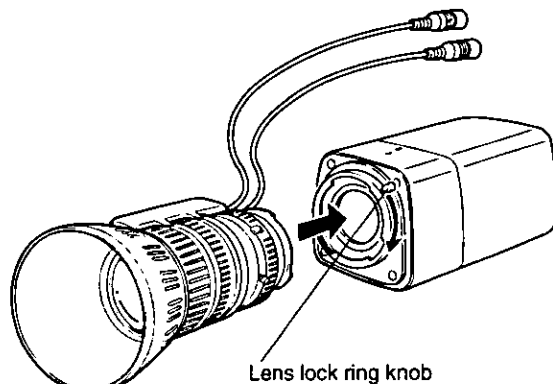

# CONNECTIONS

- Before making any connection, switch off all the components of the system.
- Use the control panel AC Adaptor AW-PS301 (optional) and Pan/tilt Head AC Adaptor AW-PS300 (optional).

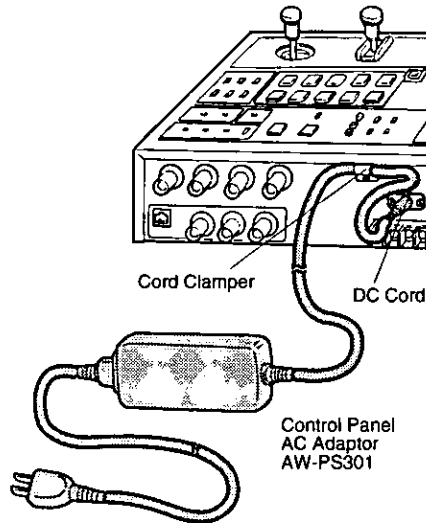

- Use the pan/tilt AW-PH300 and the Color Video Camera WV-E550 or AW-E560. To connect the pan/tilt head to the camera, the Camera Cable AW-CA20T15 (optional) is necessary.
- Locally purchase a DC cable with a nominal cross section of 1.25 mm<sup>2</sup> or larger that meets the UL specifications, and connect the Pan/tilt Head AW-PH300 to the Pan/tilt Head AC Adaptor AW-PS300 with that cable. The maximum distance between the pan/tilt head and pan/tilt head AC adapter is 30 m.
- Connect the AC Adaptor AW-PS301 to the control panel and clamp the DC cable of the AC adaptor to the cord clamp on the control panel.
- Connect the Pan/tilt Head AW-PH300 to the Color Video Camera WV-E550 or WV-E560 with the Camera Cable AW-CA20T15.

- Connect the iris control cable of the motor-driven zoom lens to the camera and the remote (zoom/focus control) cable to the pan/tilt head. If the remote (zoom/focus control) cable of the motor-driven zoom lens is connected to the camera, the lens cannot be controlled.

- Connect the control panel to the pan/tilt head with the three coaxial cables (video signal, G/L signal, camera control signal) and one 10BASE-T straight cable (pan/tilt head control signal). The maximum distance between the control panel and pan/tilt head is 500 meters for coaxial cables 5C-2V and 10BASE-T cable (UTP category 5 or equivalent).
- For further details on connecting the individual devices, refer to their operating instruction manuals.

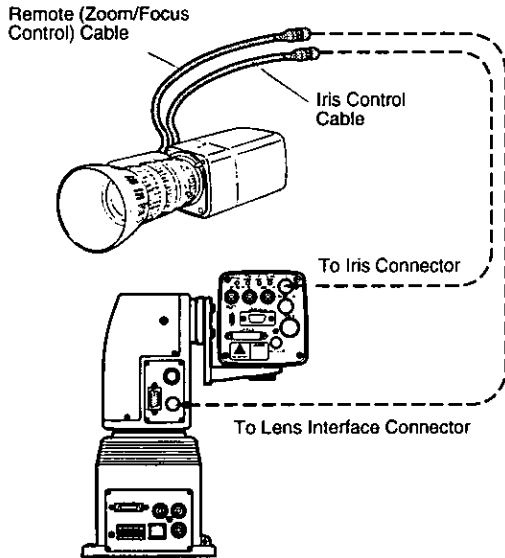



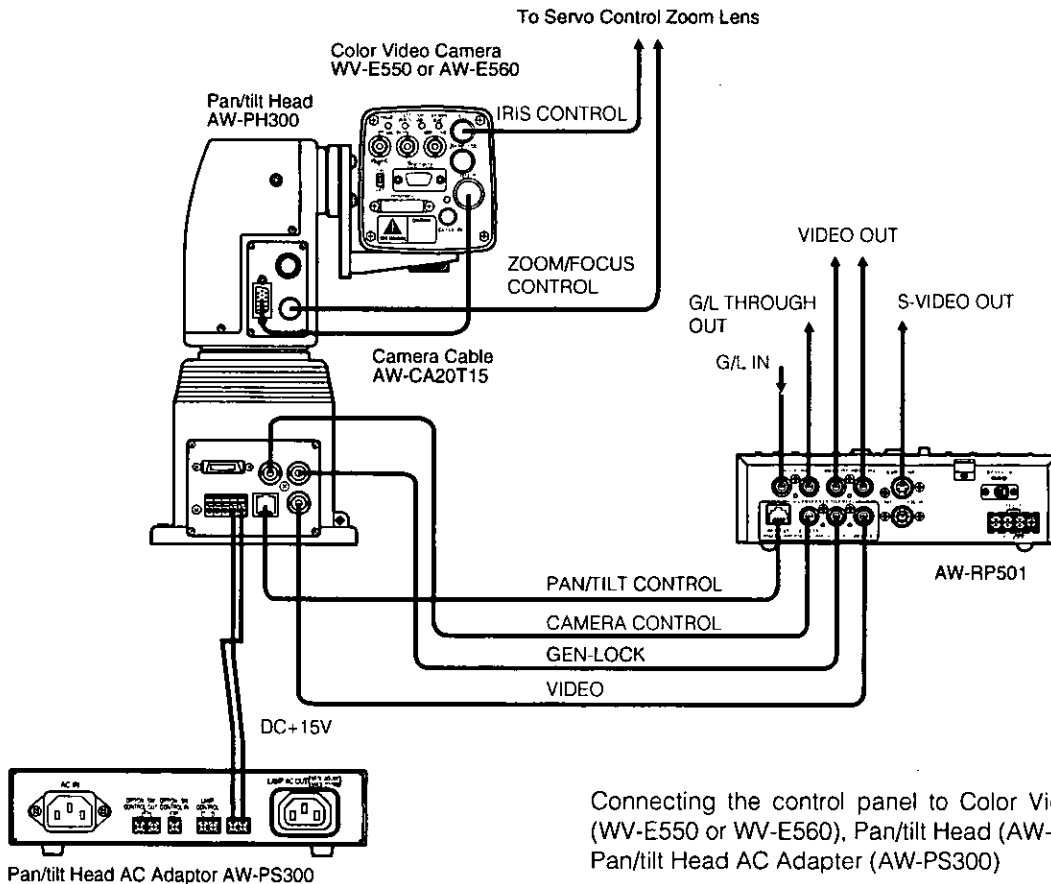

• Example of System Connection

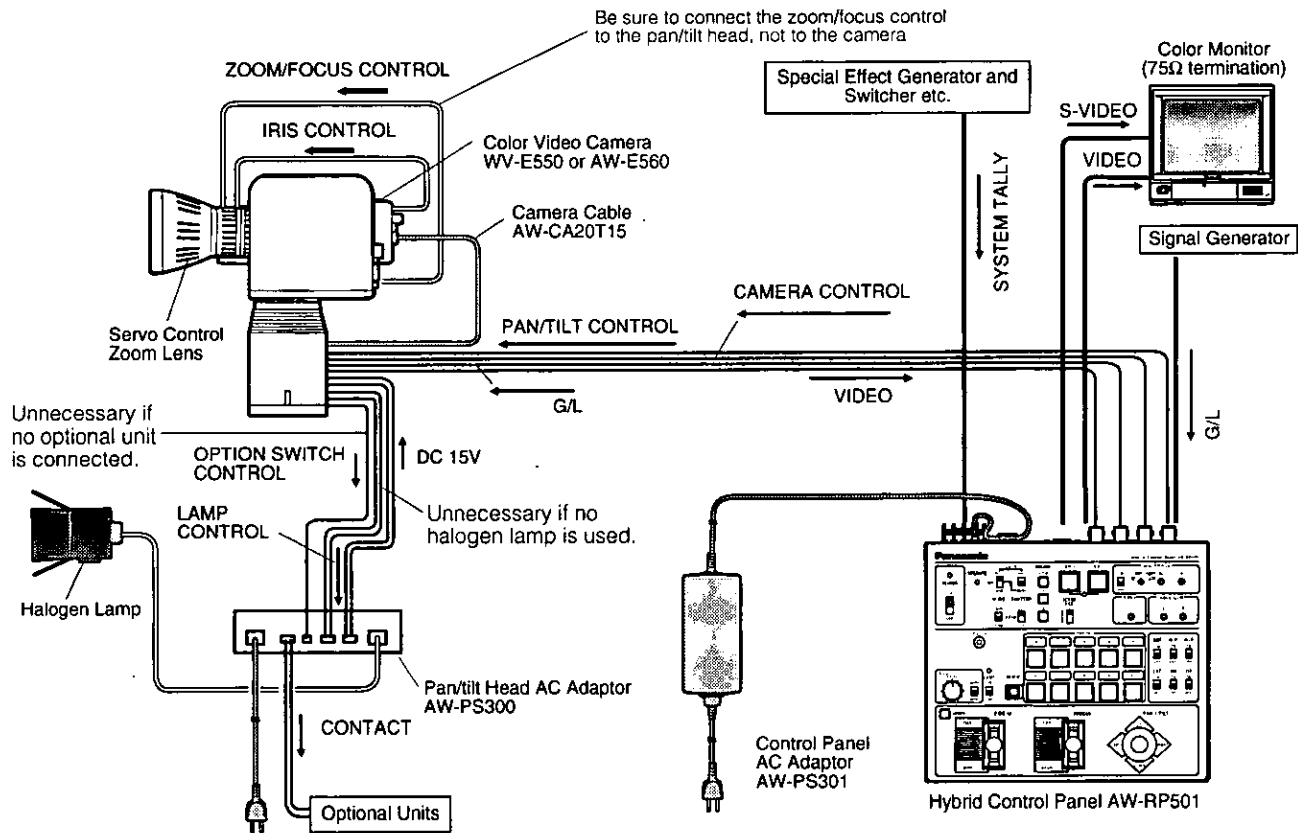

# OPERATING PROCEDURES

## 1. Power

Set the power switch on the pan/tilt head AC adapter to the ON position, then set Power ON/OFF Switch ② on the control panel to the ON position.

## 2. Pan/tilt Limiter Setting for Pan/tilt Head

If there are obstacles around the pan/tilt head, set the limiters to limit the operating range (pan left and right ends, tilt up and down ends) of the pan/tilt head.

**Note:** The switches on the pan/tilt head have been pre-set before shipment from the factory on the assumption that the pan/tilt head would be suspended from the ceiling. If the pan/tilt head is mounted on a board, for example, be sure to shift the mounting direction switches on the pan/tilt head. Unless this is done, pan/tilt directions will be reversed and pan/head operation limiter data cannot be properly stored in the memory. For details on shifting these switches, refer to INSTALLATION OF PAN/TILT HEAD at page 18 or the Operating Instructions for Pan/tilt Head.

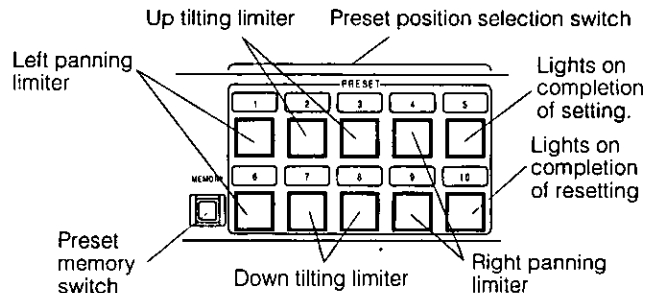

### ① Left Panning Limiter

Turn the pan/tilt head to the desired left panning limit with PAN/TILT Lever ⑳, keep MEMORY Switch ㉗ depressed, and simultaneously press buttons [1] and [6] of PRESET Switches ㉘ for 5 seconds or more. When the desired limit has been set, button [5] of PRESET Switches ㉘ lights.

To reset the limit, keep the MEMORY switch ㉗ depressed, and simultaneously press buttons [1] and [6] of PRESET Switches ㉘ again for 5 seconds or more. When the set limit is reset, button [10] of PRESET Switches ㉘ lights.

② Right Panning Limiter

Turn the pan/tilt head to the desired right panning limit with PAN/TILT Lever 39, keep MEMORY Switch 27 depressed, and simultaneously press buttons [4] and [9] of PRESET Switches 28 for 5 seconds or more. When the desired limit has been set, button [5] of PRESET Switches 28 lights.

To reset the limit, keep the MEMORY Switch 27 depressed, and simultaneously press buttons [4] and [9] of PRESET Switches 28 again for 5 seconds or more. When the set limit is reset, button [10] of PRESET Switches 28 lights.

③ Up Tilting Limiter

Turn the pan/tilt head to the desired up tilting limit with PAN/TILT Lever 39, keep MEMORY Switch 27 depressed, and simultaneously press buttons [2] and [3] of PRESET Switches 28 for 5 seconds or more. When the desired limit has been set, button [5] of PRESET Switches 28 lights.

To reset the limit, keep the MEMORY switch 27 depressed, and simultaneously press buttons [2] and [3] of PRESET Switches 28 again for 5 seconds or more. When the set limit is reset, button [10] of PRESET Switches 28 lights.

④ Down Tilting Limiter

Turn the pan/tilt head to the desired down tilting limit with PAN/TILT Lever 39, keep MEMORY Switch 27 depressed, and simultaneously press buttons [7] and [8] of PRESET Switches 28 for 5 seconds or more. When the desired limit has been set, button [5] of PRESET Switches 28 lights.

To reset the limit, keep the MEMORY switch 27 depressed, and simultaneously press buttons [7] and [8] of PRESET Switches 28 again for 5 seconds or more. When the set limit is reset, button [10] of PRESET Switches 28 lights.

### 3. Cable Compensation Setting, Genlock and Total Pedestal Adjustment

#### • Cable Compensation

Signal degradation due to cable length between the control panel and the pan/tilt head can be compensated for.

- ① If the cable length from the pan/tilt head to the control panel is longer than 300 meters, set the cable compensation switch on the pan/tilt head to the ON position. For details, refer to INSTALLATION OF PAN/TILT HEAD at page 18 or the Operating Instructions for Pan/tilt Head.
- ② Connect a waveform monitor or a vectorscope to the VIDEO OUT connector 47 on the control panel, set the MODE BAR/CAM Switch 4 to the BAR position, then observe the color bar signals.
- ③ Adjust the Y (luminance) signal level with CABLE COMP Y Control 20, then adjust the C (chrominance) signal level with CABLE COMP C Control 21. Repeat this until the video output of the control panel is adjusted as shown in the figure below.  
**Note:** Turning CABLE COMP Y Control 20 changes not only the Y (luminance) signal level but also the video signal levels as a whole.

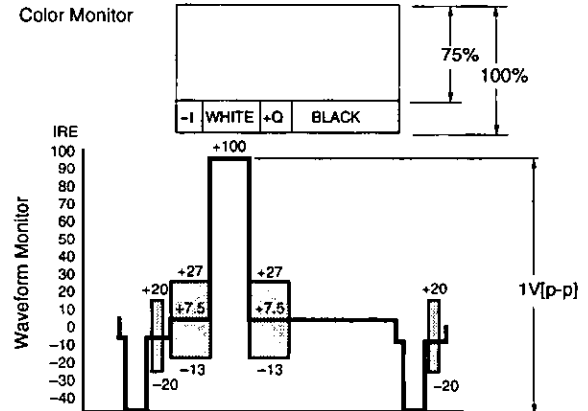
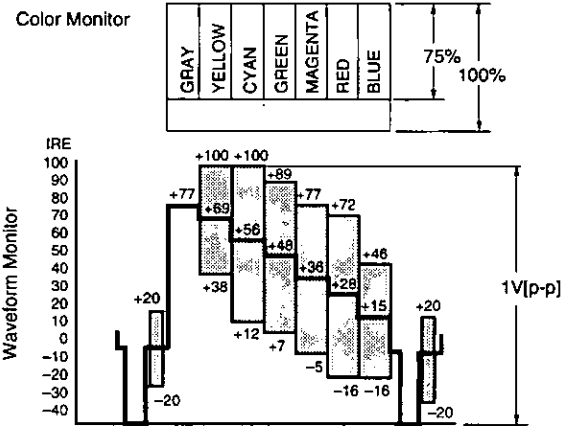

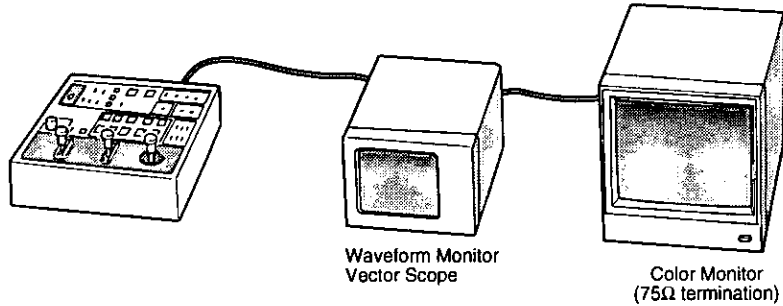

• **Genlock Adjustment**

To use the camera in external sync mode, phase adjustment is necessary to match the phases with those of the other units and camera. No G/L adjustment is necessary in case of no genlock.

• **Horizontal Phase Adjustment**

- ① Set G/L PHASE ON/OFF Switch 15 to the ON position.  
**Note:** When G/L PHASE ON/OFF Switch 15 is set to the ON position, the sync phase of the camera changes to the settings of G/L PHASE H Control 18, G/L PHASE Coarse Switch 16, and G/L PHASE SC Control 17. Unless G/L phase adjustment is necessary, do not set G/L PHASE ON/OFF Switch 15 to the ON position.
- ② Observe the waveforms of the G/L signal input (black burst signal) and video signal output on a dual channel oscilloscope, and turn the G/L PHASE H control 18 to

- match the horizontal phase as shown in the figure right.
- ③ Set G/L PHASE ON/OFF Switch 15 back to the OFF position.

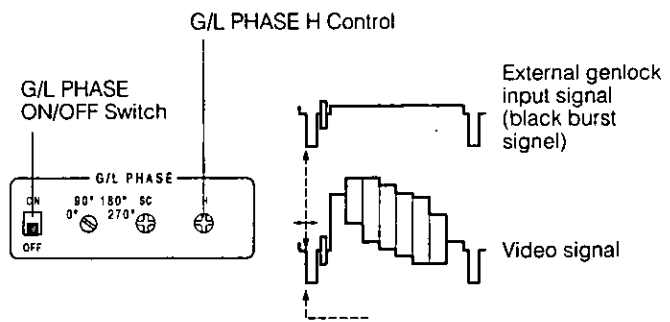

• **Subcarrier Phase Adjustment**

- ① Set G/L PHASE ON/OFF Switch 15 to the ON position.  
**Note:** When G/L PHASE ON/OFF Switch 15 is set to the ON position, the sync phase of the camera changes to the settings of G/L PHASE H Control 18, G/L PHASE Coarse Switch 16, and G/L PHASE SC Control 17. Unless G/L phase adjustment is necessary, do not set G/L PHASE ON/OFF Switch 15 to the ON position.
- ② Adjust G/L PHASE Coarse Switch 16 and G/L PHASE SC Control 17 to match the subcarrier color phase of the video signal output with that of the reference tone, such as of the program output (split-color bar output) of a Color Special Effect Generator, for example. Higher accuracy can be obtained if a vectorscope is used for color phase adjustment.
- ③ Set G/L PHASE ON/OFF Switch 15 back to the OFF position.

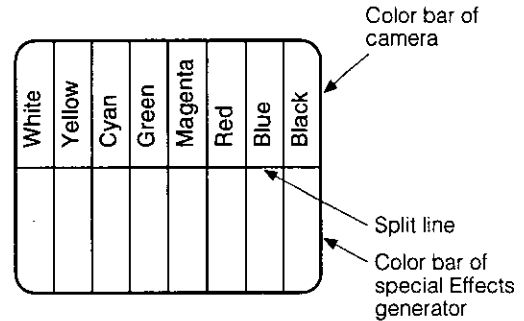
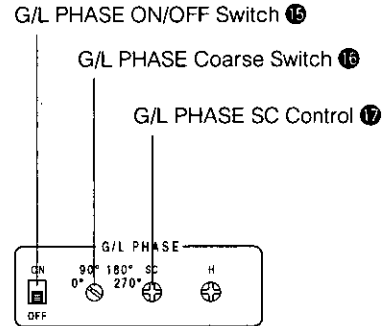

## • Total Pedestal Adjustment

Total pedestal adjustment is made to adjust the pedestals of two or more cameras. Using an oscilloscope or a waveform monitor, adjust the pedestals to 5 IRE (0.035 V) or 7.5 IRE (0.050 V) with T.PED Control 19.

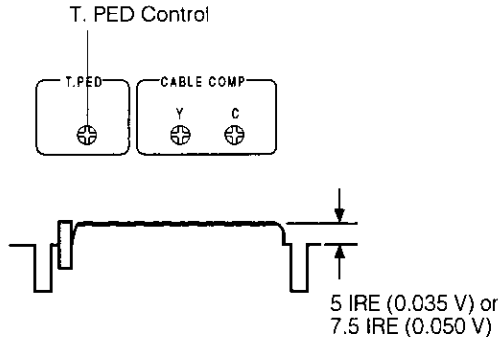

## 4. White Balance Setting

- White balance adjustment is necessary when using the camera for the first time, or if the camera has not been used for a long period of time.
- Once the white balance is adjusted, no readjustment is necessary if the camera is used under the same conditions.

### • Automatic White Balance Control (AWC)

The color temperature conditions for two channels A and B can be stored in the memory in advance. Once the white balance is adjusted, all that is needed is to select either AUTO/ATW A Switch 9 or AUTO/ATW B Switch 10 if the camera is used under the same conditions. No readjustment is necessary. If the white balance is readjusted, the existing white balance data is replaced with new data.

- ① Press either AUTO/ATW A Switch 9 or AUTO/ATW B switch 10.
- ② Pick up a white object (a white wall or white handkerchief, for example) fully on the screen. Be careful to keep a shiny or bright object out of the screen.
- ③ When AWC Switch 11 is pressed, Auto Set Indicator 13 flashes and the white balance is automatically adjusted. It goes out when it has been properly adjusted. If the adjustment fails, Auto Set Indicator 13 remains lit. In such a case, change the brightness, iris, object, light source, etc. and adjust it again.



- **Automatic Tracing White Balance Control (ATW)**

When AUTO/ATW ATW Switch ⑧ is pressed, the white balance is automatically adjusted even if the light source or color temperature changes, thus reproducing a natural image.

**Note:** The white balance may deviate if there is nothing white in the image. The white balance may not be fully adjusted depending on the light source or color temperature.

## 5. Black Balance Setting

- Black balance adjustment is necessary when using the camera for the first time, or if the camera has not been used for a long period of time.
- Black balance adjustment is necessary if there is a big change in the ambient temperature or at the turn of a season.
- Once the black balance is adjusted, no readjustment is necessary if the camera is used under the same conditions.

- **Automatic Black Balance Control (ABC)**

When ABC Switch ⑫ is pressed, the lens iris is automatically closed to set the black balance. Keep IRIS AUTO/MANU Switch ⑮ in the AUTO position when setting the black balance. Auto Set Indicator ⑬ flashes during black balance adjustment, and goes out when it is finished normally. Auto Set Indicator ⑬ remains lit if the adjustment fails. In such a case, try to adjust it again.

Black balance adjustment may fail in some cases where the total pedestal is too low. Adjust the total pedestal with T.PED Control ⑰ and adjust the black balance again.

## 6. Camera and Pan/tilt Head Presetting

- ① Pick up a desired object with the camera using PAN/TILT Lever ③⑧ ZOOM Lever ③⑥ and FOCUS Lever ③⑦. Select a white balance control mode using AUTO/ATW ATW Switch ⑧ AUTO/ATW A Switch ⑨ or AUTO/ATW B Switch ⑩. To store iris data in the memory, set IRIS AUTO/MANU Switch ②⑤ to the MANU position and turn the iris control. When IRIS AUTO/MANU Switch ②⑤ is in the AUTO position, iris data will not be stored in the memory.
- ② Keep MEMORY Switch ②⑦ depressed (MEMORY Switch ②⑦ lights and all the 10 buttons of PRESET Switches ②③ flash), press any of the buttons [1] to [10] of PRESET Switches ②③ as desired to store the data in the memory. Only that button of PRESET Switches ②③ where the data is stored lights.

**Note:** If data is stored again in the same button of PRESET Switches ②③ the preceding data is deleted.

## 7. Various Switch Settings

Set the gain, shutter and other switches as appropriate to the conditions of using the camera.

## 8. Camera and Pan/tilt Head Operation

Control the camera and pan/tilt head using PRESET Switches ②③ PAN/TILT Lever ③⑧ ZOOM Lever ③⑥ FOCUS Lever ③⑦ IRIS AUTO/MANU Switch ②⑤ and other switches.

- \* In case of not changing the adjustment data and settings, it is not necessary to repeat the adjustment and setting procedures described in Sections 2 to 7.

# RACK MOUNTING

## ■ Rack Mounting

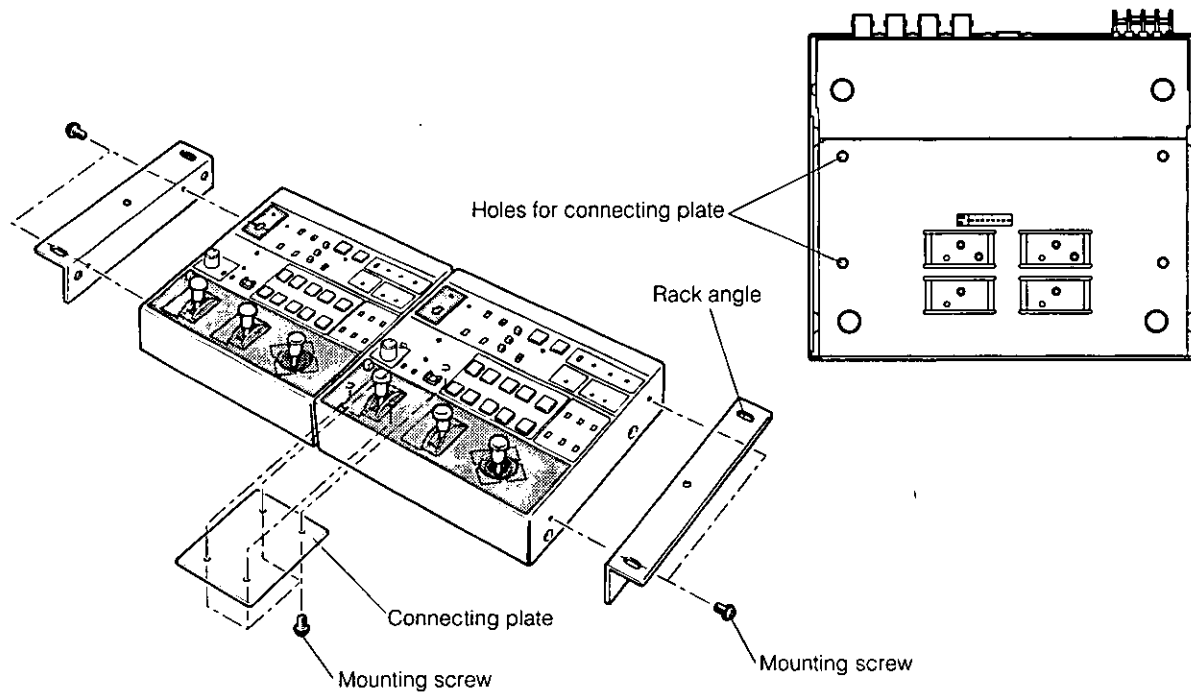

## ■ How to Change Rear Panel Direction

- ① Remove the four screws from both sides of the top cover, and take the top cover off.

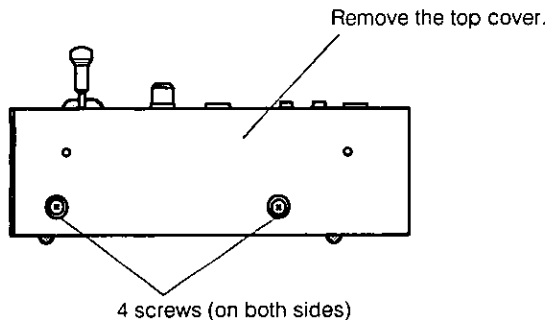

- ② Remove the two screws and take the blank panel off.

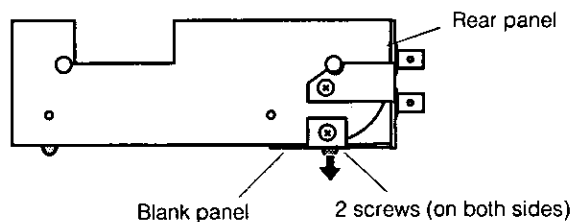

- ③ Loosen the rear panel screw, turn the rear panel down, and fasten it to the bottom.

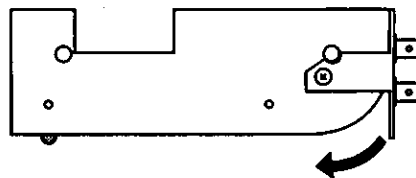

- ④ Fasten the blank panel back to the rear.

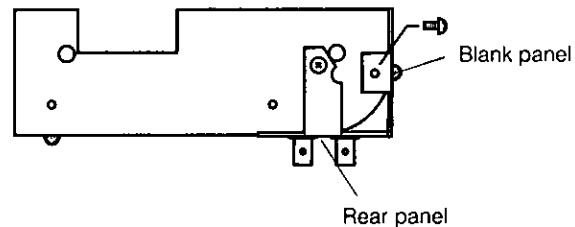
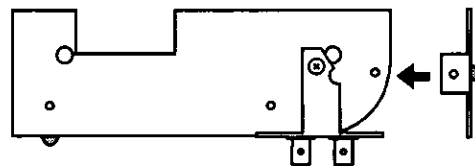

# SPECIFICATIONS

Source Voltage	12 V DC (DC jack)
Power Consumption	12V, 0.7A
Video Input	1.0 V[p-p] composite/75Ω (BNC connector)
Genlock Input	1.0 V[p-p] black burst 75Ω loop through with auto terminator (BNC connector)
Video Output	1.0 V[p-p] composite/75Ω x 2 (BNC connector)
S-video Output	Y: 0.714 V[p-p] (75 Ω) C: 0.286 V[p-p] burst level chrominance/75 Ω (S-VIDEO connector) 75Ω (BNC connector)
Genlock Output	75Ω (BNC connector)
Camera Control Output	Control signal (BNC connector)
Pan/tilt Control Output	Control signal (RJ-45 8P modular jack)
System Tally Input	Tally signal (2 pin Terminal block)
Auxiliary Control Input	Control signal (8 pin DIN connector)
Switches	Power ON/OFF Switch, GAIN HIGH/MID/LOW Switch, GAIN AGC/MANU Switch, MODE BAR/CAM switch, SHUTTER Switch, AUTO/ATW ATW switch, AUTO/ATW A switch, AUTO/ATW B switch, AWC Switch, ABC Switch, G/L PHASE ON/OFF Switch, G/L PHASE Coarse Switch, IRIS AUTO/MANU Switch, MEMORY Switch, PRESET Switch, DEF Switch, WIP Switch, H/F Switch, EXT Switch, ND Switch, OP Switch, SPEED Switch, SPEED SW CHANGE Switch, ZOOM REVERSE Switch, ZOOM/FOCUS EXCHANGE Switch, FOCUS REVERSE Switch, TILT REVERSE Switch, PAN REVERSE Switch
Controls	T. PED Control, G/L PHASE SC Control, G/L PHASE H Control, CABLE COMP Y Control, CABLE COMP C Control, IRIS LEVEL Control, ZOOM Lever, FOCUS Lever, PAN/TILT Lever
Pan/tilt Head Connecting Cable:	x 4 (Coaxial Cable 3 pcs., 10BASE-T straight cable 1 pc.)(In case of using G/L function)
Maximum cable length:	500 m (In case of using coaxial cables 5C-2V and 10BASE-T cable UTP category-5)
Operating temperature	-10°C to +45°C (14°F to +113°F)

Dimensions	210 (W) x 88 (H) x 177 (D) mm [8-1/4" (W) x 3-1/2" (H) x 7" (D)]
Weight	2.2 kg (4.9 lbs.)
Finish	AV Ivory painting

Weight and dimensions indicated are approximate.  
 Specifications are subject to change without notice.

## ACCESSORIES

Seal .....	1	Mounting screws .....	12
Rack angle .....	2	M4 x 8mm .....	8
		M5 x 8mm .....	4
		Connecting plate .....	1



# Panasonic

**Broadcast & Television Systems Company**

**Division of Matsushita Electric Corporation of America**

**Executive Office:** One Panasonic Way 3F-5, Secaucus, NJ 07094

**Regional Offices:**

**EASTERN ZONE:** 50 Meadowlands Parkway, Secaucus, NJ 07094 (201) 348-7620

**CENTRAL ZONE:** 1707 North Randall Road, Elgin, IL 60123 (847) 468-5200

**SOUTHERN ZONE:**

**Atlanta Region:** 1225 Northbrook Parkway, Suite 1-160, Suwanee, GA 30024

Panazip 11 (770) 338-6841, fax (770) 338-6741

**Law Enforcement Video Products:** 1225 Northbrook Parkway, Suite 1-160, Suwanee, GA 30024, Panazip 11 (770) 338-6844, fax (770) 338-6721

**WESTERN ZONE:**

**Seattle Region:** 1200 Westlake Ave., North, Suite 508, Seattle, WA 98109 (206) 285-8883

**Los Angeles Region:** 6550 Katella Ave. 17A-1, Cypress, CA 90630 (714) 373-7271

**Government Marketing Department:** 52 West Gude Drive, Rockville, MD 20850 (301) 738-3840

**PANASONIC CANADA INC.**

5770 Ambler Drive, Mississauga, Ontario, L4W 2T3 Canada (905) 624-5010

**PANASONIC SALES COMPANY**

**DIVISION OF MATSUSHITA ELECTRIC OF PUERTO RICO, INC.**

San Gabriel Industrial Park, 65th Infantry Ave. KM. 9.5 Carolina, Puerto Rico 00630 (809) 750-4300

N1197-0

7J1A105A

Printed in Japan